

THE TRAVELER MONEY MACHINE

WITH NEW
SMART START
TECHNOLOGY™

FROM THE MAKERS
OF THE
ORIGINAL
CASH CUBE

A Great
Promotional Tool

Rugged Powder
Coated Steel Frame!

Flashing Rope
Lighting!

New Blower Design
Blows 250 Bills!

Portable and
Programmable!

3 Models
Available!

Allow Us To
Make Your Next
Event Something
Special, Call Today!

FUN
INDUSTRIES INC.

627 15th Ave.
East Moline, IL 61244
Toll-free 1-800-747-1144
Local 309-755-5021
Fax 309-755-1684



FUN INDUSTRIES INC. TRAVELER MONEY MACHINE

IMPORTANT: PLEASE READ BEFORE OPERATING THIS MACHINE



1. After removing your machine from its shipping carton and pallet, open the main door of the machine and remove the loose contents inside of the unit. These contents should include: remote control, goggles, beacon, fabric sheets, “Stock-it-Pocket”, and optional vinyl cover.

accessories



2. Now tip the machine over on all four wheels (**assistance may be required**). Install the red beacon (if equipped) to the lid of the machine. You will find pre-wired terminals to connect and velcro to hold the beacon in place. You are now ready to move the unit to its event location. **We recommend using an assistant when loading or unloading the machine from its transportation vehicle.**

mount beacon



3. After moving the machine to its event location, stand the unit upright and unlock the blower bolt at the rear of the machine. With the bolt in the up position, pull the blower out of the rear of the unit until it stops. Now relock the blower bolt to secure the blower in place.

unlock



slide out & lock



4. Unwrap the main power cord located at the rear of the machine and plug it into a circuit rated for at least 15 amps.
NOTE: EXTENSION CORDS ARE NOT RECOMMENDED!

5. You will now need to crumple your money or coupons similar to the illustration pointed out at the right. The machine will not circulate the bills properly if they are left flat or rolled up too tight. While crumpling the bills, throw them into the machine on the floor through the main door. After you have filled your machine with **up to 150 pieces**, insert one fabric sheet into the machine as well. This reduces the amount of static build-up in the machine, which can be harmful to the electronics. Simply pull the fabric sheet out before a contestant enters the machine.



ALWAYS USE A FRESH FABRIC SHEET WHILE DISPLAYING YOUR MACHINE

6. Now step to the rear of the machine and turn the main power switch on. Unlock the control panel door to check that the program settings are what you desire. To program the machine, push the small program button inside the control panel. Every press of this button will advance you through each program option. The option number is displayed on the top two digits of the display and the setting is displayed on the bottom four digits. To change the setting of any particular option, press the yellow start button located power switch. After advancing past the last program option, the machine will go back to regular operating mode. The program options are explained below and a quick reference chart is located on the control door of the machine. Notice the auto/manual switch located in the control box as well. This switch changes your machines operation from manual mode to automatic mode. *Manual mode* is what you would normally run when contestants are being run through the machine. *Automatic mode* allows the machine to continually cycle on and off. This is used for displaying or promoting the machine.

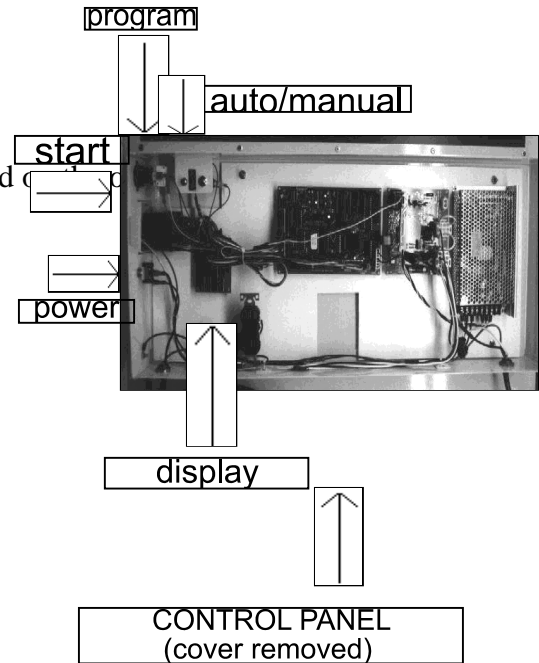

PROGRAM OPTIONS

OPTION	DESCRIPTION	FACTORY SETTING	MAXIMUM	INCREMENTS BY
#1	Manual mode run time	15	60	1
#2	Automatic mode run time	15	60	1
#3	Automatic mode pause time	20	600	10
#4	Ropelight with blower on (1=flash, 0=steady burn)	1	1	1
#5	Ropelight with blower off (1=on, 0=off)	1	1	1
#6	Ropelight flash timer (milliseconds)	150	2000	50

6. Your machine should now be ready for operation. Before placing a contestant inside the unit, turn the auto/manual switch in the rear control panel to automatic and allow the machine to cycle a few times. Then you should turn it back to manual and get your contestant prepared to enter the unit. **We recommend using safety goggles with all contestants.** If you are using the “Stock-it-Pocket” for your event, now is a good time to hang it in the slot on the outer front wall. The “Stock-it-Pocket” helps limit the amount of bills a contestant keeps, for it is quite difficult to shove the money through the slot on the front wall. After explaining your particular rules (see rules sheet) to the contestant, open the door and place them inside the machine. Once ready, press the yellow start button on the control panel. After the blower has completed its cycle and all bills have fallen to the floor, help your contestant exit the machine and remove the “Stock-it-Pocket” from the unit. **Repeat these simple steps with each new contestant and expect your event to be a success!!!**

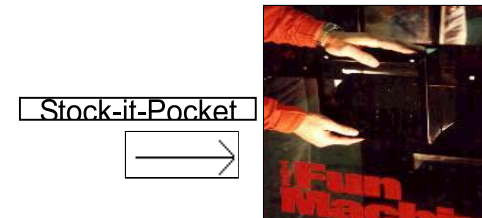
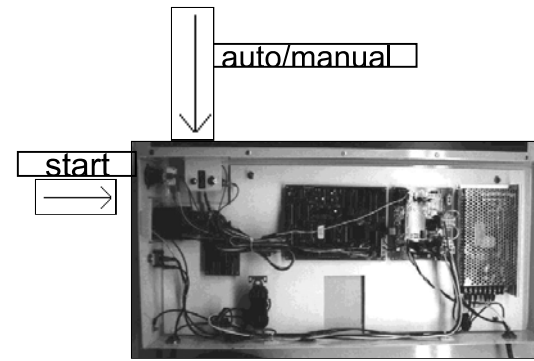

8. After your event is over, it is now time to prepare the unit for its return home. First remove all bills or coupons left over on the floor of the machine. Also if used, remove the “Stock-it-Pocket” from the front wall. Next unplug the main power cord and wrap it to the bracket on the rear of the machine. Now lift the blower lock and slide the blower into the unit. Once the blower is all the way in, relock the bolt. This will retain the blower in place while moving the machine. Remove the beacon (if used) and make sure that all accessories are enclosed in their carton and place them on the floor of the unit. Now tip the machine over on its wheels (**assistance may be required**) and install the vinyl cover (optional). With the machine on all four wheels, move it to its transportation vehicle and have someone assist you loading the machine. Once you return home with the machine you may want to clean and prep it for your next event.

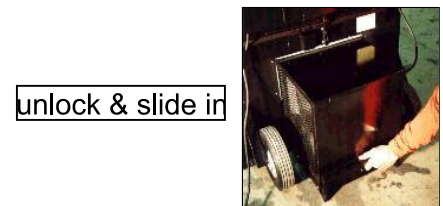

IF YOU REQUIRE FURTHER ASSISTANCE
PLEASE CALL US AT 1-800-747-1144
Monday thru Friday, 8am to 5 pm central



TROUBLESHOOTING TRAVELER MONEY MACHINE

SYMPTOM

POSSIBLE SOLUTION

1. NO POWER

- A. Check that main cord is plugged in.**
- B. Check that power switch is on.**

2. NOT BLOWING PROPERLY

- A. Check that blower is pulled out the rear**
- B. Check that money or coupons have been crumpled.**
- C. Check that the intake on the blower is not blocked and that the vent on the ceiling is open as well.**
- D. Check that no more than 150 pieces are in machine.**

3. FRONT DISPLAYS NOT WORKING

- A. Check the connections at the side and top of each display, they may have worked loose during transportation.**

4. ERRATIC OPERATION

- A. This is usually caused by static electricity. Always use a fresh static sheet when displaying machine.**

CLEANING

We recommend using a mild detergent or glass cleaner with a soft cloth for cleaning. Your machine is manufactured with an abrasion resistant coating but if not treated correctly you may damage the finish. A soft cloth is the key to cleaning your machine. Replacement panels are also available from our factory. You may also need to remove the front deflector on the floor of the machine for periodic cleaning.

**IF FURTHER ASSISTANCE IS NEEDED, PLEASE CALL
1-800-747-1144 M-F 9am-4pm**

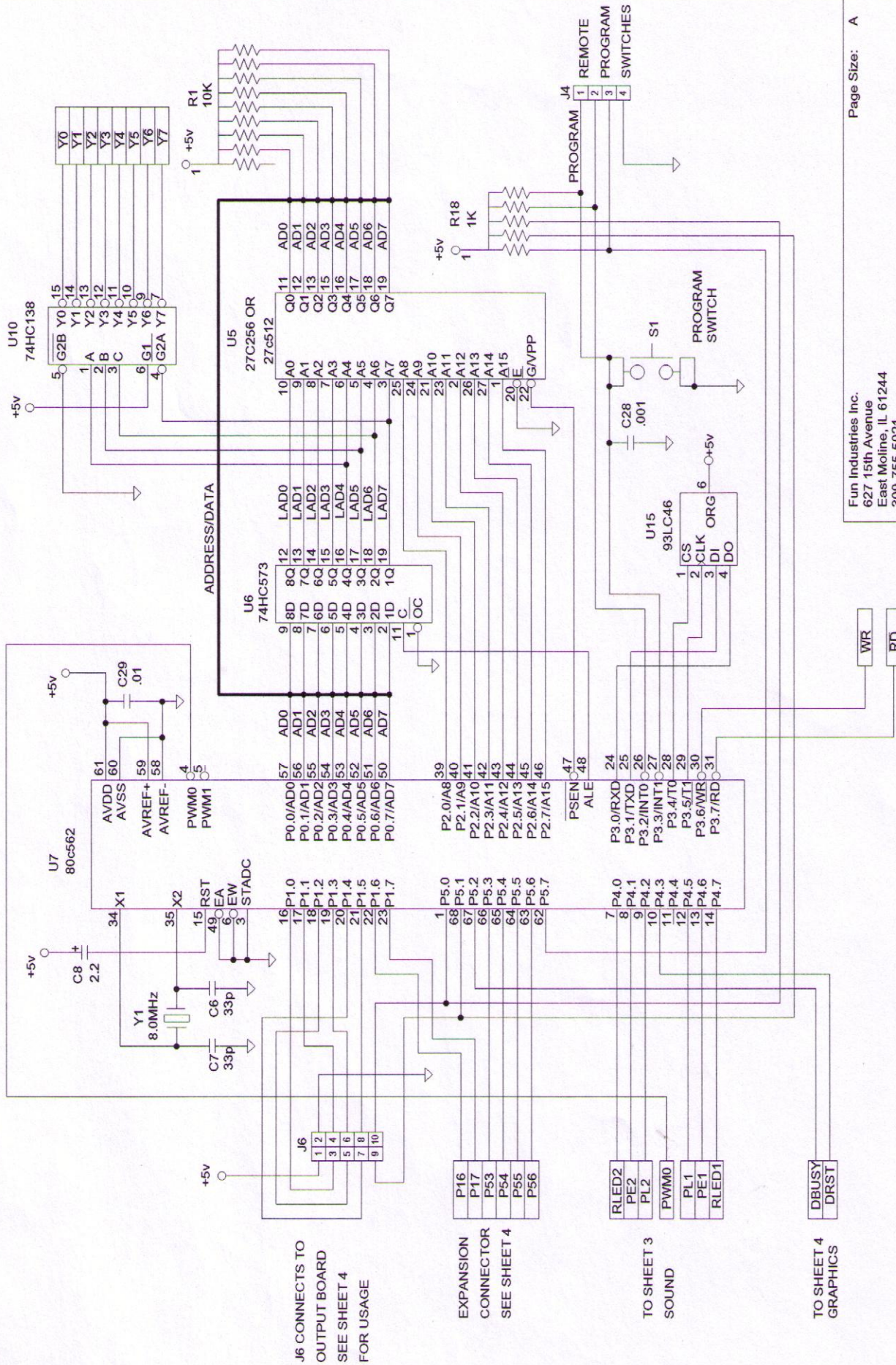

J6 CONNECTS TO
OUTPUT BOARD
SEE SHEET 4
FOR USAGE

EXPANSION
CONNECTOR
SEE SHEET 4

TO SHEET 3
SOUND

TO SHEET 4
GRAPHICS

Fun Industries Inc.
627 15th Avenue
East Moline, IL 61244
309-755-5021

SC1780 Game Board Assembly - Microprocessor Core

Revision: A

April 27, 1996

Page 1 of 4

Page Size: A

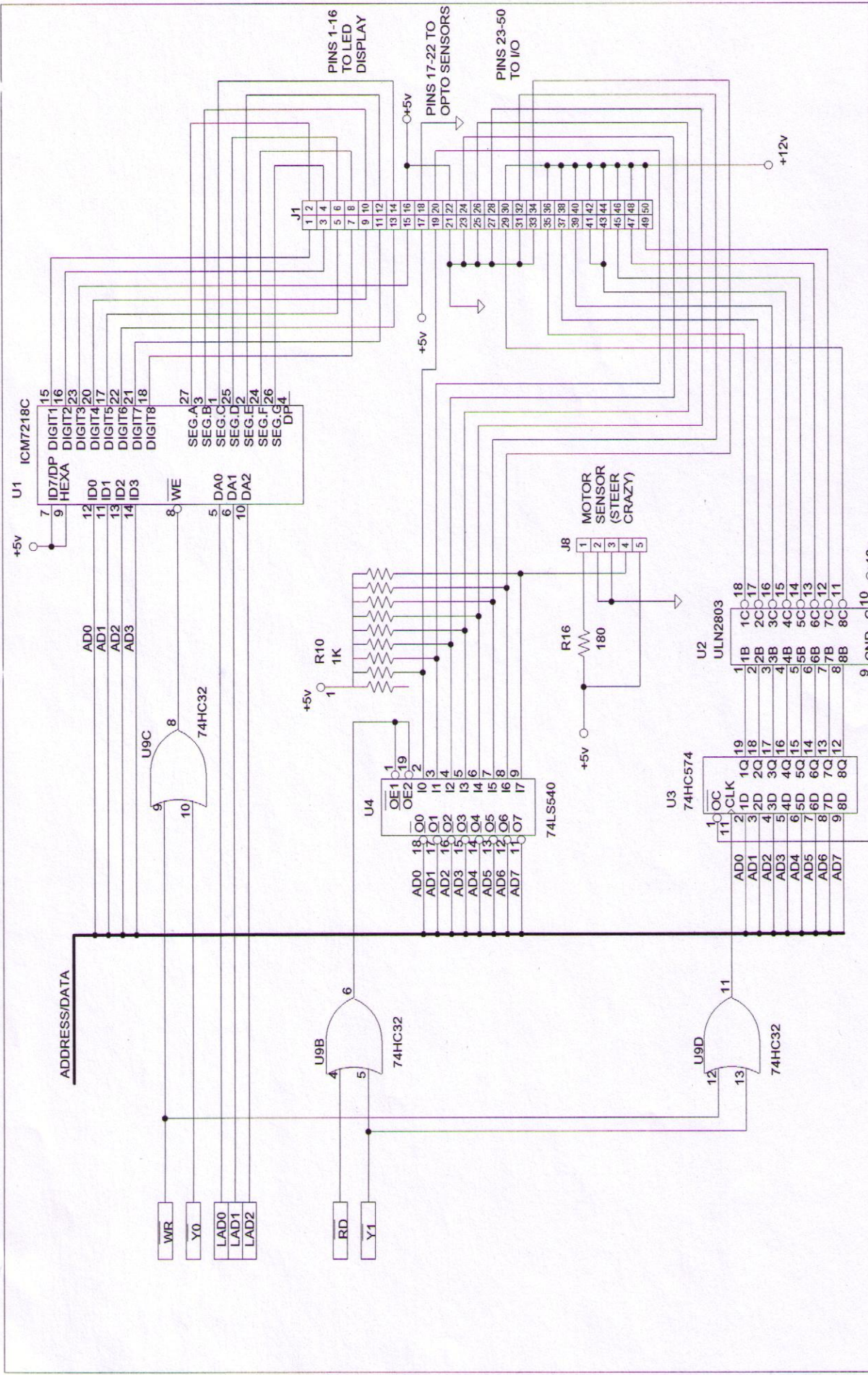

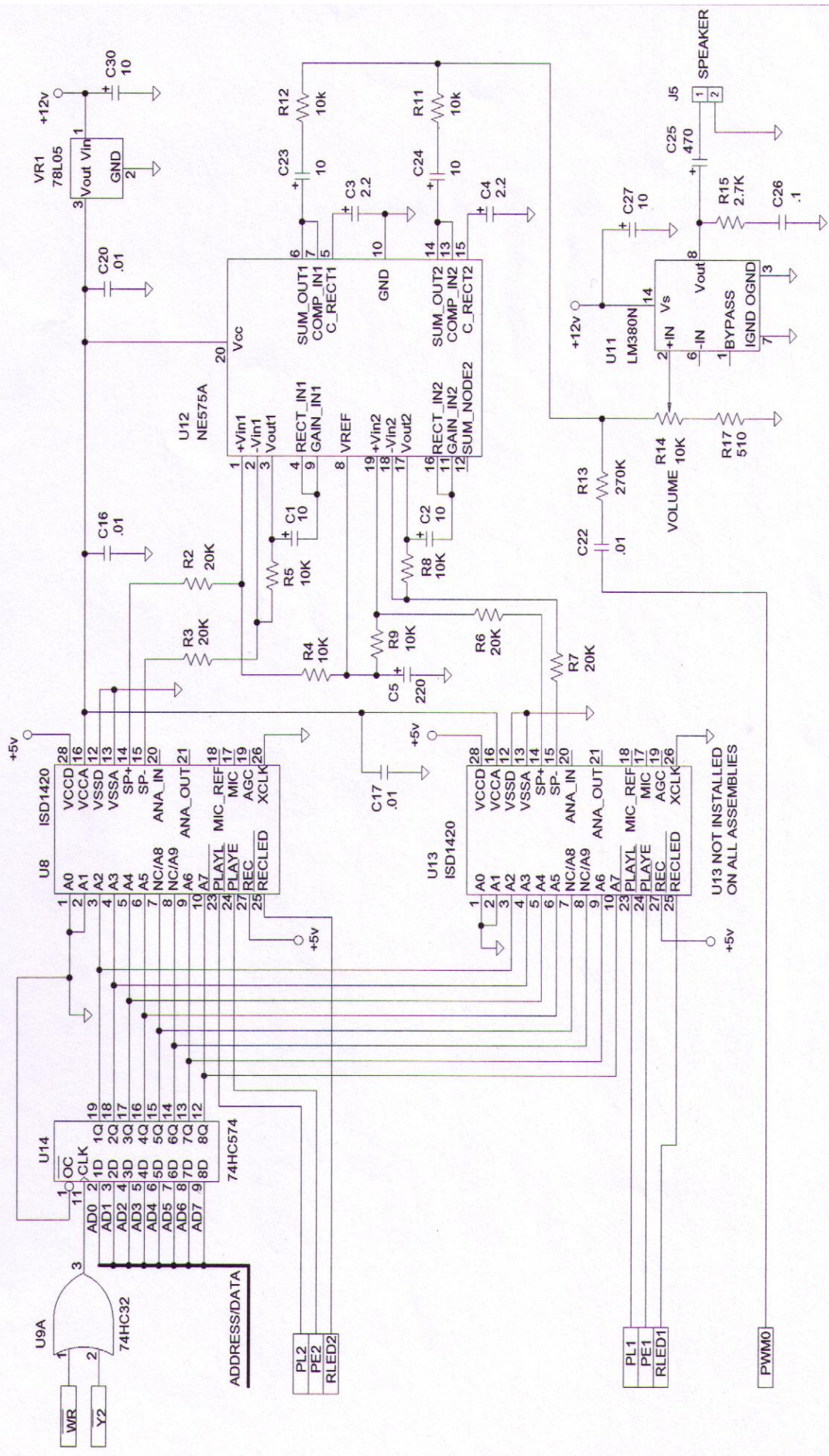

UNLESS OTHERWISE NOTED:
RESISTANCE VALUES ARE IN OHMS
CAPACITANCE VALUES ARE IN MICROFARADS

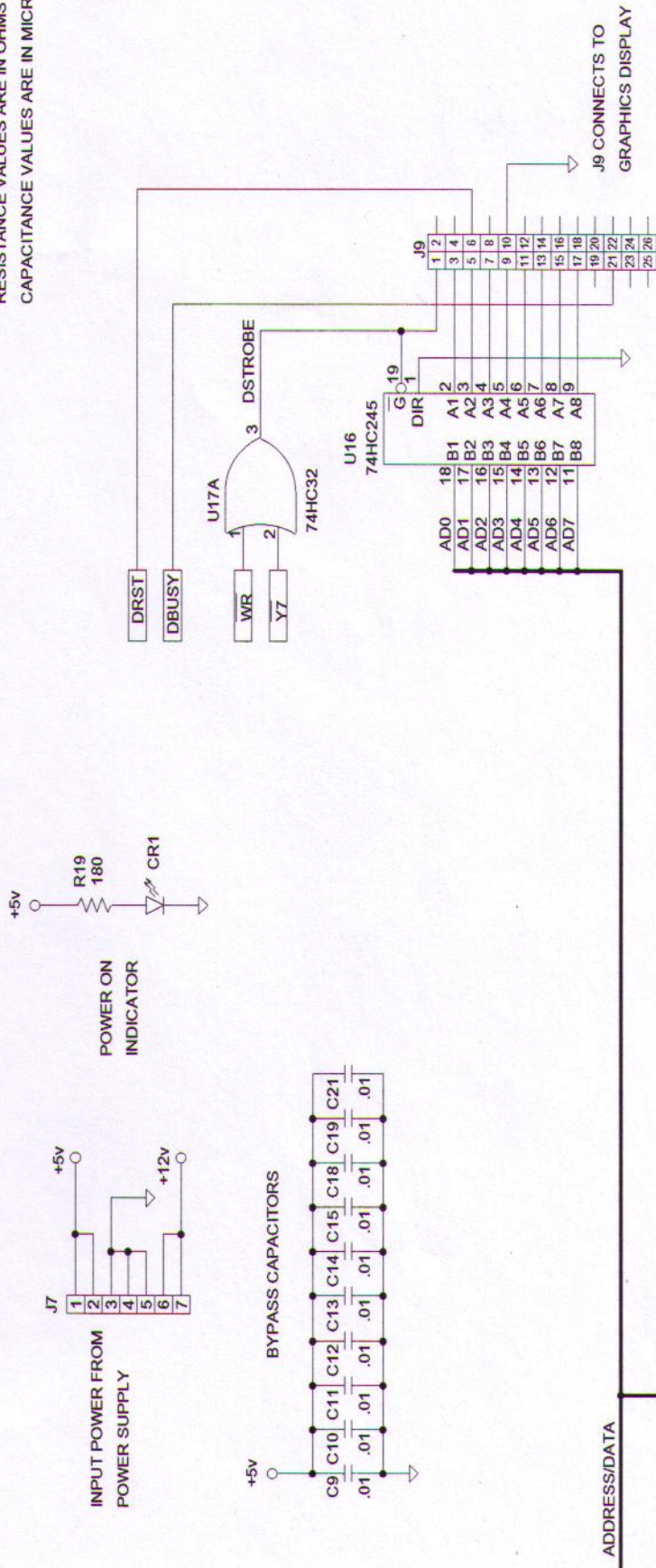

NORMAL USAGE FOR OUTPUT BOARD CONNECTOR - J6

- PIN 1 - +5 VOLTS
- PIN 2 - GND (SIGNAL COMMON)
- PIN 3 - AC OUTPUT 1 (PLAYWHEEL, VEND, OR BLOWER MOTOR)
- PIN 4 - AC OUTPUT 2 (TRAVELLER LIGHTS, SPARE, OR NOT INSTALLED)
- PIN 5 - TICKET VENDOR ENABLE
- PIN 6 - BEACON
- PIN 7 - SPARE DC OUTPUT (NOT INSTALLED)
- PIN 8 - KICKER OUTPUT (IF APPLICABLE)
- PIN 9 - TICKET NOTCH SENSOR
- PIN 10 - SPARE DC INPUT

J2 AND J3 PROVIDE CONNECTIONS TO FUTURE EXPANSION DAUGHTERBOARD

Fun Industries, Inc.
627 15th Avenue
East Moline, IL 61244
309-755-5021

SC1780 Game Board Assembly - Power, Graphics, Expansion Connector

Revision: A

April 27, 1996

Page 4 of 4

Page Size: A